



ROYAL CHANGEABLE-POINT LIVE CENTERS

*Accuracy is guaranteed to be $\pm 0.00005"$ TIR as long as the points are installed on the live center to which they have been match-ground. When a customer purchases a new point, we recommend sending the live center back to our factory so we can grind the new point to it. This service is free to Royal customers.

Two precision angular contact bearings help achieve good rpm and load ratings.

Shank, head, and points (except #4 blank point), are hardened for wear resistance and long life.

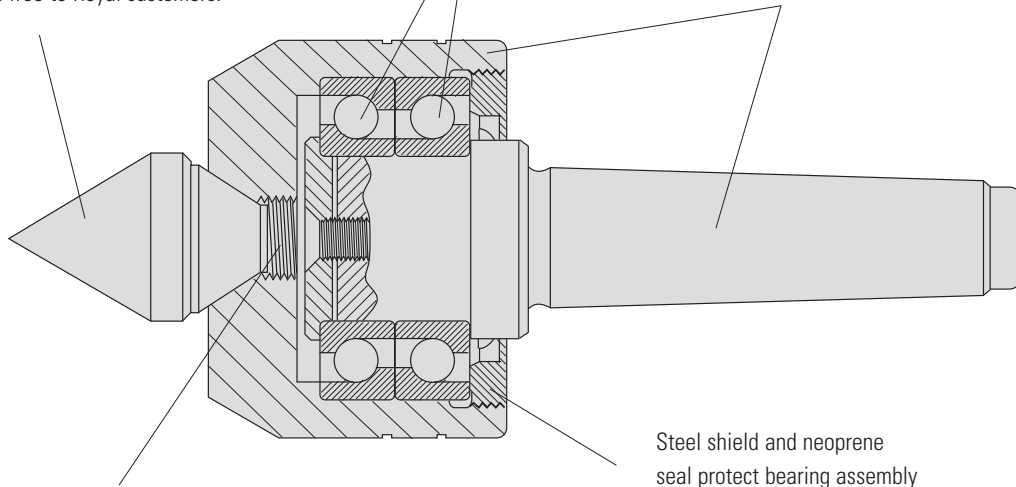

Precision ground tapers and single-lead threads ensure that **points consistently seat in the same location** when they are interchanged, providing maximum accuracy.

Steel shield and neoprene seal protect bearing assembly from coolant and chips for extended operating life.



- ❑ This versatile live center uses interchangeable points to handle many common turning jobs.
- ❑ Each center includes a #3 standard 60° male point. Other points sold separately.
- ❑ $\pm 0.00005"$ TIR guaranteed.*
- ❑ Unique taper/thread design allows points to be easily interchanged and ensures accuracy.



Check out the Royal Live Center Video at www.livecenters.com

ROYAL CHANGEABLE-POINT LIVE CENTERS

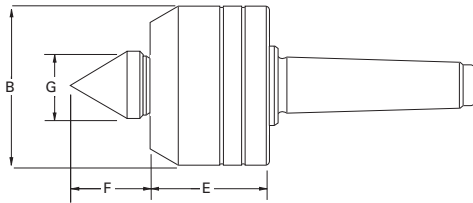

Royal Changeable-Point Live Centers

TAPER	B	E	F	G	POINT THREADS	MAX. SUGGESTED RPM*	WEIGHT OF WORKPIECE (lbs.)	THRUST LOAD (lbs.)	PART NUMBER	PRICE
2 MT	2.00	1.85	1.13	0.88	5/8" - 18	6,000	390	960	10002	\$754
3 MT	2.38	2.07	1.25	1.00	5/8" - 18	5,000	500	1,140	10003	823
4 MT	3.50	2.64	1.79	1.50	3/4" - 16	3,500	1,070	1,810	10004	1,237
5 MT	3.50	2.64	1.79	1.50	3/4" - 16	3,500	1,070	1,810	10005	1,325

* Maximum recommended operating limit. Operating above this speed could result in heat build-up and accelerated bearing wear.



1



2



3



4



5

1. Pipe point for pipe and tubing work.
2. Extra-long male point for additional tool clearance.
3. Standard male point.
4. Blank point made of unhardened 4140 steel.
5. Female point for work not having a center-hole.

Individual Points for Changeable-Point Live Centers

POINT	2 MT				3 MT				4 & 5 MT			
	DIA.	"F" DIM.	PART NUMBER	PRICE	DIA.	"F" DIM.	PART NUMBER	PRICE	DIA.	"F" DIM.	PART NUMBER	PRICE
1	0.75-2.12	1.67	10061	\$386	0.88-2.38	1.75	10071	\$311	1.38-3.50	2.38	10091	\$486
2	0.88	1.66	10062	269	1.00	1.88	10072	268	1.38	2.34	10082	333
3	0.88	1.13	10063	248	1.00	1.25	10073	257	1.50	1.79	10083	264
4	0.88	1.13	10064	152	1.00	1.25	10074	121	1.38	1.66	10084	168
5	0.19-0.91	0.92	10065	242	0.25-1.06	1.15	10075	325	0.25-1.38	1.28	10085	305