

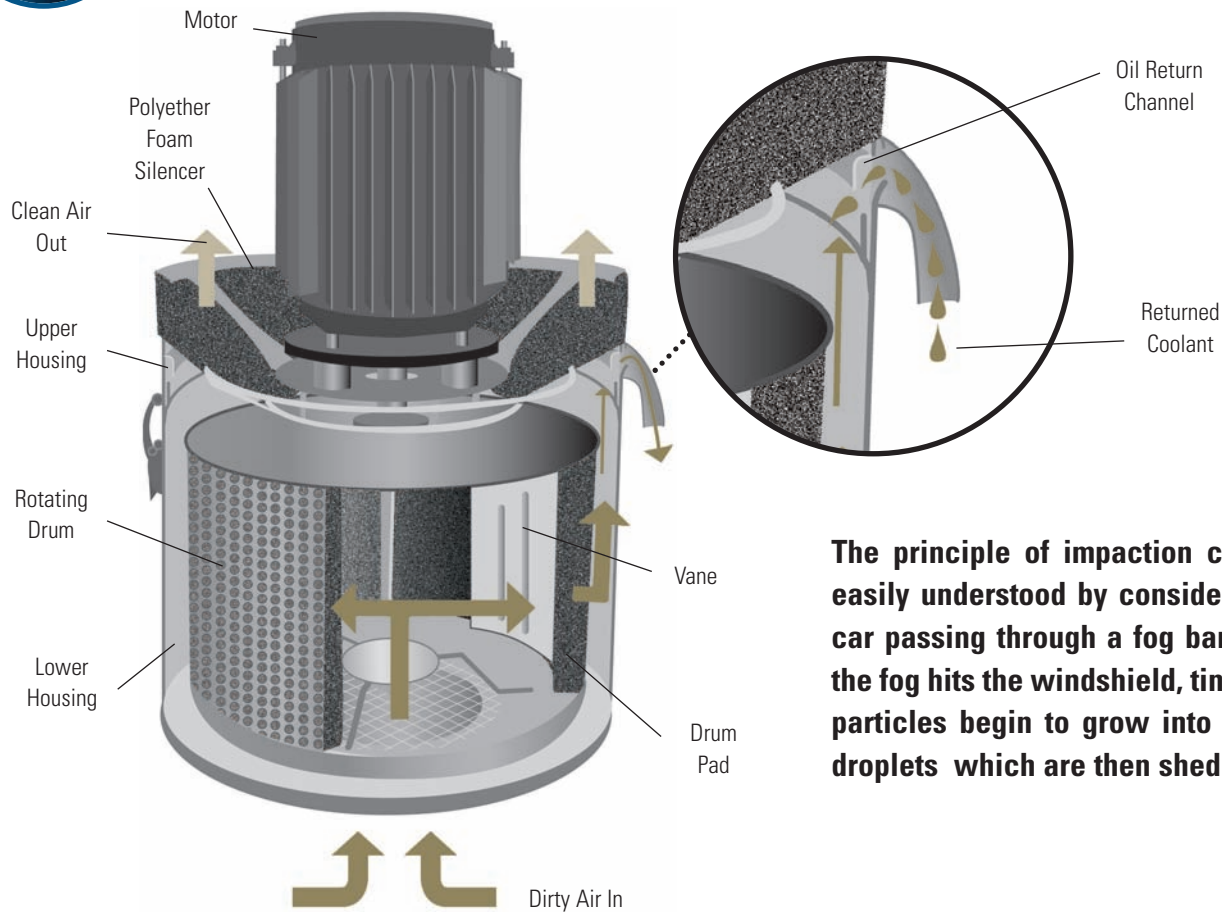

## HOW DOES THE ROYAL FILTERMIST WORK?



**The principle of impaction can be easily understood by considering a car passing through a fog bank. As the fog hits the windshield, tiny mist particles begin to grow into water droplets which are then shed off.**

**The Royal Filtermist uses the principle of centrifugal impaction to eliminate mist. With only three main components: a drum, a motor, and the housing, its operation is quite simple.**

1. A three-phase motor rotates the internal drum at high speed, creating a vacuum which draws mist particles into the center of the drum.
2. The mist particles then collide with the rotating drum's vanes and are forced together with other particles, causing them to coalesce and form larger, droplet-sized particles.
3. As the particles grow into droplets, they pass through the perforations in the rotating drum and centrifugal force causes them to be thrown onto the inner wall of the housing.
4. The particles are then forced, under pressure, up the walls of the housing to the oil return channel, where they are subsequently drained back to the machine's coolant tank.
5. Clean, oil-free air blows past the motor and is returned to the shop.
6. Since this process relies on the mechanical principle of centrifugal impaction and the rotational speed remains constant, **the Royal Filtermist maintains a continuous high efficiency.**
7. For certain applications that produce smoke and/or very fine mist particles, an after filter may be required. This filter easily mounts to the top of the Filtermist unit by slipping over the motor and it is secured in place with two toggle clips. An after filter mounted to a Royal Filtermist typically enjoys a comparably long service life because most contaminants are removed by the impaction process prior to reaching the filter.

**Note – it is important to understand that the pads that line the Filtermist drum are not filters. These porous pads are present to slow airflow through the unit, thereby maximizing contact with the drum vanes for greatest overall impaction efficiency.**

**IMPORTANT — All Filtermist units should be electrically wired to run continuously throughout a standard shift. Units should never be wired to switch on and off with the machining cycle. Please see installation manual for additional information.**